

1. - BOLTS FOR PEDESTAL CAP BOLTS TO BE REAMED AND REAVED FOR 1/2 DIA BOLTS HAVE 1/8 DRILLING FIT IN BED.

ENLARGED DETAIL OF JACKING PAD

WELD ENLARGED SECTION

4 HOLES TAP 1/8 SW R.H. ENGINE NO 3482 TO 3540 CLASS 25 ONLY
2 HOLES 1/8 DIA R.H. CLASS 25 ONLY

SECTION Y-Y TO BE REAMED FOR 1/8 DIA FITTED BOLTS FOR ROCKING GRATE CYLINDER SEE DRG NO 66

SECTION X-X

11-3" ROCKER PLATE TO BE LOCATED FROM 1/2 RADIUS BAR FULCRUM

HALF BOTTOM PLAN

1" DRILL BY G.S.C. 2" BORE 1/2" DEEP BY LOCO BLDG BUILDER FOR ROCKING GRATE CYLINDER SEE DRG NO 66

2 HOLES 1/8 DIA R.H. ONLY CLASS 25 ONLY

SECTION AT CENTER

SECTION R-R

SECTION T-T SECTION S-S

THIS SPACE FOR PATTERN NUMBER AND MARKINGS, R.S. ONLY.

ROCKER PLATE TO BE WELDED TO BED AT SIDES AND ENDS BY G.S.C.

SIDE ELEVATION TO BE REAMED FOR 1/8 DIA FITTED BOLTS COMMON WITH PLATFORM SUPPORTS R.H.

SECTION W-W 2 HOLES TAP 1/8 SW CLASS 25 ONLY

SECTION U-U

ENLARGED SECTION THRU RADIUS BAR FULCRUM

2 HOLES TAP 1/8 SW R.H. ONLY
2 HOLES TAP 1/8 SW R.H. ONLY

1" STUDS 5/8" DRILL 1/4" DEEP

1/8" DRILL REAM FOR 3/8" BOLTS BY LOCO BLDG

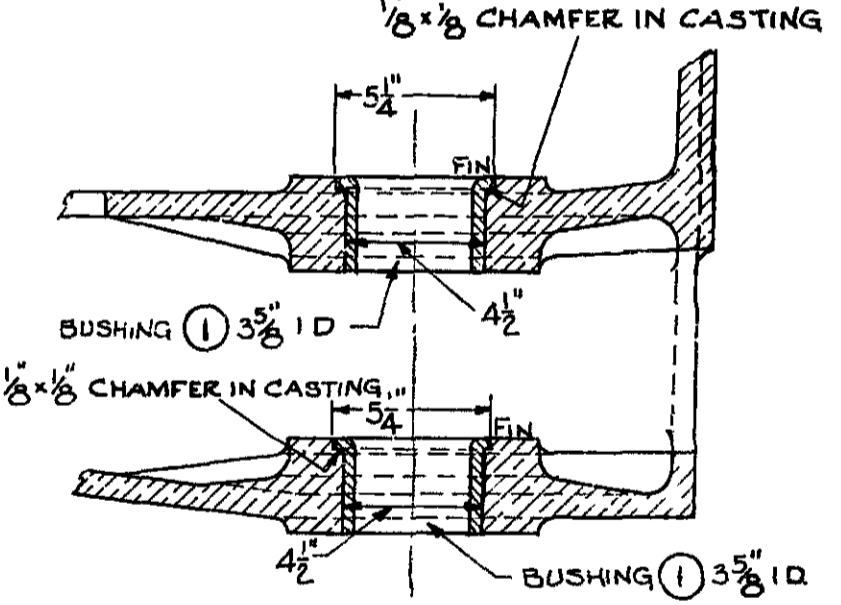

ENLARGED SECTION 7-7

SUPPLIED BY - COMMONWEALTH SALES CORPORATION EDDYSTONE PA U.S.A.

REAR END ELEVATION

2 HOLES 1/8 DIA CLASS 25 ONLY

4 HOLES 3/8" DIA FOR 1/2" DIA BOLTS CLASS 25 ONLY FOR REAMED FOR 3/8" DIA FITTED BOLTS COMMON WITH PLATFORM SUPPORT & CONDENSING PIPE

FINISH FOR MACHINED OR GROUND SURFACES
AFWERKING VAN MASJINAALBEWERKTE OF GESLYPTE VLAKKE

AMENDMENTS	
WYSIGINGS	
SOUTH AFRICAN RAILWAYS	
SUID-AFRIKAANSE SPOORWEE	
ORDER NO 815157	S.A. REFERENCE CON B/C 3839
BESTELLING NR 815157	S.A. VERWYSING KON B/C 3839
CONTRACT FOR 50 LOCOMOTIVES & TENDERS CLASS 25 NC FOR 50 LOKOMOTIEVE EN KOLEWAGENS KLAS 25N L	
KONTRAKT VIR 50 LOKOMOTIEVE EN KOLEWAGENS KLAS 25N L	
CONTRACTOR'S NAME NORTH BRITISH LOCOMOTIVE CO LTD GLASGOW	
KONTRAKTEURSAAM NENSCHTEL & SOHN G.M.B.H. KASSEL	
CONTRACTOR'S DRAWING NO 52-2641	
KONTRAKTEURSTEKENING NO 52-2641	
S.A. ENGINE	BOILER NO 10015-1064
S.A. S. LOKOMOTIEF NR 3481-3540	KETEL NR
BED CASTING HIND END	
SCALE	1" = 1'-0"
SKAAL	1" = 1'-0"
C. E. N. A. 197	
15681	
INSPECTOR'S SIGNATURE	DATE
INSPEKTOURSHANDTEKENING	DATUM 26.3.1927

MICROBOX